

# AMICUS Separator Kit Performance Report

**Important: If reaction or injury has occurred call Fresenius Kabi Post-Market Quality Assurance at 1-800-933-6925.**

Incident Date: \_\_\_\_\_ Instrument S/N.: \_\_\_\_\_ Software Version: \_\_\_\_\_ UDI No.: \_\_\_\_\_  
 Product Code: \_\_\_\_\_ Lot No.: \_\_\_\_\_

**When Was the Problem Detected?**

Set Up  Prime \_\_\_\_\_%  Exchange  Depletion  Depletion/Exchange  Reinfusion  After Procedure/QC

**Problem Type (Mark all applicable)**  Cut/Slice  Kink  Particulate Matter  Restriction/No Flow  
 Alarms (Specify) \_\_\_\_\_  Leak  Separated  Blood Leak  
 Cracked  Excess Air  Missing  RBC Contamination  Other (Specify Below)

**Please answer the following questions:**

1. Was there any adverse event or injury? Yes  No
  2. If applicable, list name of any drug administered: \_\_\_\_\_
  3. Was the procedure successfully completed? Yes  No  N/A
  4. If no, was the procedure stopped due to a soft goods incident? Yes  No  N/A
  5. Was product lost? Yes  No  N/A
- Check box if you do **NOT** wish to receive response letters.

\_\_\_\_\_ E-mail address for letter recipient (if applicable)

**Please circle specific components on the diagram where incident occurred**

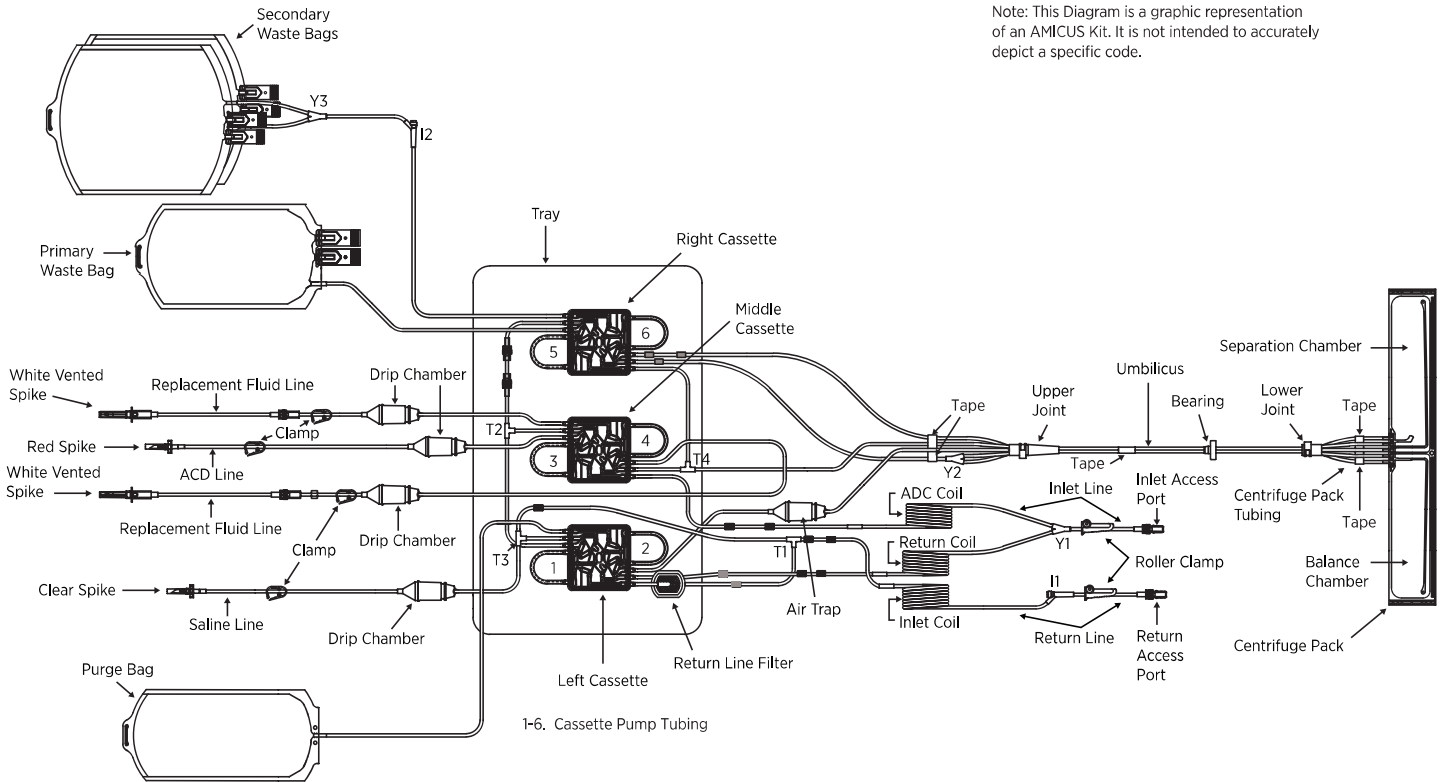

**Additional Problem Description / Explanation**

**Kit Return To Fresenius Kabi**

1. Sample available for evaluation? Yes  No  Not Required
  2. Sample return box needed? Yes  No  Return label only
  3. Picture available for evaluation? Yes  No
- Please e-mail a clear picture **along with this report** to **mdpmqa.usa@fresenius-kabi.com**

**Center Authorized Signature/Date:**

**Fax this report to 1-888-858-2983 or E-mail to mdpmqa.usa@fresenius-kabi.com and include a copy of this form when returning a kit.**

**Customer Information (please print)**

**The following information is required to receive a credit**

Facility Name: \_\_\_\_\_  
 Contact Person: \_\_\_\_\_  
 Account Number (if known): \_\_\_\_\_  
 Operator Name: \_\_\_\_\_  
 Street Address: \_\_\_\_\_  
 City/State/Zip: \_\_\_\_\_  
 Phone Number: \_\_\_\_\_  
 Contact Person's E-mail: \_\_\_\_\_