



**FRESENIUS
KABI**

caring for life

Produktkatalog Catalogue de produits Catalogo prodotti

Transfusion, Autotransfusion, Cell Processing



Schweiz/Suisse/Svizzera 2024

about us

Fresenius Kabi ist ein weltweit tätiges Gesundheitsunternehmen, das lebensnotwendige Medikamente und Medizintechnik zur Infusion, Transfusion und klinischen Ernährung anbietet. Unsere Produkte und Dienstleistungen werden in der Therapie und Versorgung von kritisch und chronisch kranken Patientinnen und Patienten eingesetzt. Das umfangreiche Produktportfolio umfasst intravenös zu verabreichende generische Arzneimittel, Infusionstherapien, klinische Ernährung und die dazugehörigen Medizinprodukte zur Applikation.

Im Bereich der Transfusionstechnologie bietet Fresenius Kabi Produkte für die Gewinnung und Verarbeitung von Vollblut und Blutkomponenten, sowie für die Autotransfusionsmedizin und die Zelltherapie an.

Fresenius Kabi est une société mondiale de santé qui propose des médicaments essentiels et des technologies médicales dans le domaine de la perfusion, la transfusion et la nutrition clinique. Nos produits et services sont utilisés dans la thérapie et les soins des patientes et patients atteints de maladies critiques et chroniques. Le vaste portefeuille de produits comprend des médicaments génériques à administrer par voie intraveineuse, des thérapies par perfusion, la nutrition clinique et les dispositifs médicaux d'application correspondants.

Dans le domaine de la technologie transfusionnelle, Fresenius Kabi propose des produits pour la collecte et le traitement du sang total et des composants sanguins, ainsi que pour la médecine d'autotransfusion et la thérapie cellulaire.

Fresenius Kabi è un'azienda sanitaria globale che fornisce farmaci e dispositivi medici essenziali per infusione, trasfusione e nutrizione clinica. I nostri prodotti e servizi sono utilizzati per la terapia e la cura di pazienti affetti da malattie critiche e croniche. L'ampio portafoglio prodotti comprende farmaci generici per somministrazione endovenosa, terapie infusionali, nutrizione clinica e i relativi dispositivi medici per l'applicazione.

Nel campo della tecnologia trasfusionale, Fresenius Kabi offre prodotti per la raccolta e la lavorazione del sangue intero e degli emocomponenti, nonché per la medicina autotrasfusionale e la terapia cellulare.



Table of content

Transfusion

Amicus Separator	4
Amicus Blue	5
AmiCORE	6
Aurora	7
DXT Data Management System	8
Solutions ACD-A & InterSol	9
Inline-Systems CompoFlow & CompoSelect	11
Bloodbags CompoFlex & CB & Transfer pack	12
Filter BioR & CompoStop	16
Accessoires	17
CompoGuard®	18
CompoSeal® Mobilea II.....	20
CompoMat® G5 Plus	21
CompoLab TM	22
Manual Plasma Extractor.....	23

Autotransfusion

CATSmart®	24
-----------------	----

Cell Processing

LOVO.....	26
CUE.....	27

Amicus Separator



Ein hocheffizienter Zellseparator für therapeutische Verfahren und Blutkomponentenspende

Séparateur de cellules très efficace pour les procédures thérapeutiques et le don de composants sanguins

Separatore di cellule ad alta efficienza per procedure terapeutiche e donazione di componenti del sangue

Art. No.	Information			Unit
6R4590	Amicus Blutzellseparator	Amicus séparateur	Amicus separatore	1
6R4590TH-M	Amicus Blutzellseparator (für Therapie)	Amicus séparateur (pour thérapie)	Amicus separatore (per la terapia)	1
R6R2317C	Amicus Set PLT, Einnadel Verfahren CC	Set Amicus PLT, uniponction CC	Set Amicus PLT, punzione singola CC	6
R6R2326C	Amicus Set MNZ-Apherese CC	Set Amicus CMC aphérèse CC	Set Amicus MNZ aferesi CC	6
R6R2339C	Amicus Plasma Exchange Kit CC	Amicus kit d'échange plasmatique CC	Amicus plasma kit di ricambio CC	6

Amicus Blue



Amicus Blue - Extrakorporale online Photopherese (ECP)

Amicus Blue - Photophérèse extracorporelle en ligne (ECP)

Amicus Blue - Fotoferesi extracorporea online (ECP)

Art. No.	Information	Unit
6R4582	Amicus Blue Phelix Photoaktivierung Amicus Blue Phelix appareil photoactivation Amicus Blue Phelix app. fotoattivazione	1
X7R2346C	Amicus Set ECP, Ein-/Zweinadel Verf. CC Set Amicus ECP, uni-/biponction CC Set Amicus ECP, uni-/bipunzione CC	6

AmiCORE

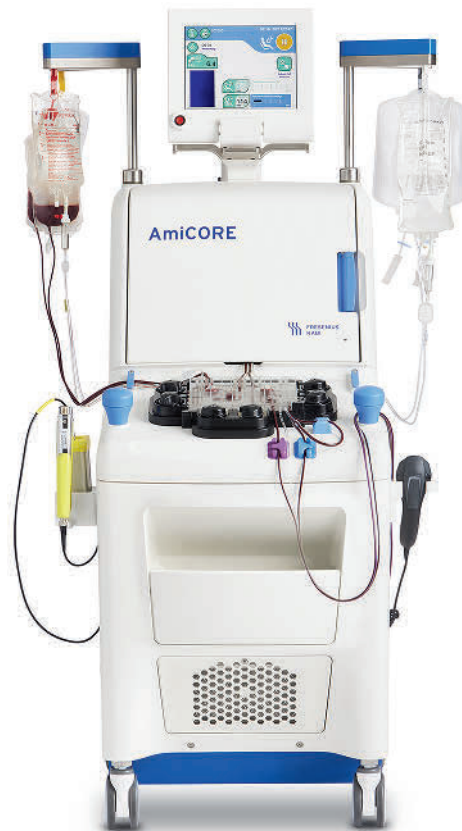

AmiCORE trägt dazu bei, jeden Schritt der Thrombozyten Sammlung zu vereinfachen.

AmiCORE contribue à simplifier chaque étape de la collecte des plaquettes.

AmiCORE aiuta a semplificare ogni fase del processo di raccolta delle piastrine.

Art. No.	Information			Unit
6R8800	AmiCORE System	Système AmiCORE	Sistema AmiCORE	1
R6R8883C	AmiCORE Set CC, 3 Lagerungsbeutel	Set AmiCORE CC, 3 poches de conserv.	Set AmiCORE CC, 3 sacco di conserv.	8
R6R8889C	AmiCORE Set CC, 2 Lagerungsbeutel	Set AmiCORE CC, 2 poches de conserv.	Set AmiCORE CC, 2 sacco di conserv.	8

Aurora

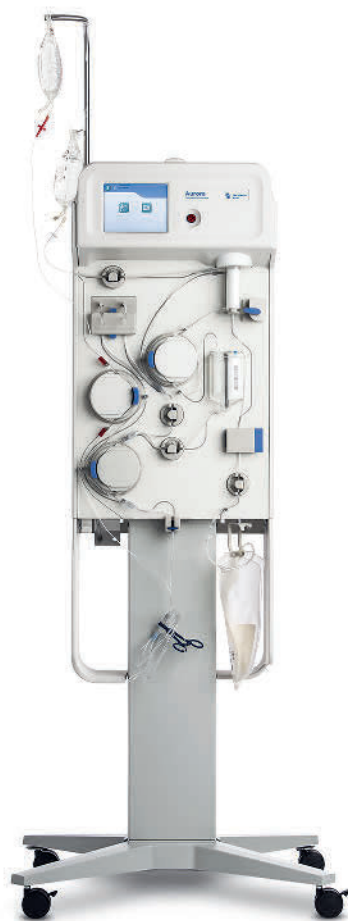

Aurora ermöglicht eine hocheffiziente und spenderschonende Sammlung von nahezu zellfreiem Plasma¹.

Aurora permet de collecter du plasma quasiment exempt de cellules¹, de manière très efficace et sans risque pour les donateurs.

Aurora consente una raccolta altamente efficiente e facile per il donatore di plasma virtualmente privo di cellule¹.

¹ Smith JK. Transfusion 1994; 15; 343-350

Art. No.	Information			Unit
6R4601	Aurora Plasmapheresesystem	Aurora système de plasmaphérèse	Aurora sistema basato su plasmaferesi	1
6R2278	Plasmacell-C Einwegset	Plasmacell-C set à usage unique	Plasmacell-C set monouso	18
6R2279C	Plasmacell-C Einwegset CC	Plasmacell-C set à usage unique CC	Plasmacell-C set monouso CC	18

DXT Data Management System



**Apherese devices,
CompoGuard, CompoMat**



DXT



**DXT
Apheresis Procedure
Record**

DXT dient als Schnittstelle und generiert eine elektronische Kopie des Verfahrensdatensatzes, um eine vollständige und genaue Dokumentation der Verfahrensergebnisse zu gewährleisten.

DXT sert d'interface et génère une copie électronique de la fiche de procédure afin de garantir une documentation complète et précise des événements de la procédure.

DXT serve da interfaccia e genera una copia elettronica del record della procedura per garantire una documentazione completa e accurata degli eventi della procedura.

Art. No.	Information			Unit
WB2100EG201	WiFi Box	WiFi Box	WiFi Box	1
6112687959	Gerätehalter für WiFi Box	Support d'appareil pour WiFi Box	Supporto dispositivo per WiFi Box	1
6212004261	Netzkabel für WiFi Box, 12VDC	Câble d'alimentation WiFi Box, 12VDC	Cavo di alimentazione WiFi Box 12VDC	1
6212004264	Datenverbindungskabel RJ45 zu RS232	Câble de connexion de dates RJ45 à RS232	Cavo di connessione dati RJ45 a RS232	1
X6S9830USB	DXT USB Stick	Clé USB DXT	Chiavetta USB DXT	1
X6S9850	DXT Lizenz	Licence DXT	Licenza DXT	1

*eine Lizenz pro Anwendungsserver nötig

*un certificat licence est requis par serveur

*una licenza per ogni server applicativo

Solutions

TS14015 ACD-A 500 ml



TS14019 ACD-A 1000 ml



TC14025 ACD-A 500 ml CC



TC14029 ACD-A 1000 ml CC



RGR8109B InterSol PAS 280 ml



RGB8110B InterSol PAS 500 ml



Art. No.	Information			Unit
TS14015	ACD-A Antikoagulans Lösung 500ml	ACD-A solution anticoagulante 500 ml	ACD-A soluzione anticoagulante 500 ml	14
TS14019	ACD-A Antikoagulans Lösung 1000ml	ACD-A solution anticoagulante 1000 ml	ACD-A soluzione anticoagulante 1000 ml	8
TC14025	ACD-A Antikoagulans Lösung 500ml CC	ACD-A solution anticoagulante 500 ml CC	ACD-A soluzione anticoagulante 500 ml CC	14
TC14029	ACD-A Antikoagulans Lösung 1000ml CC	ACD-A solution anticoagulante 1000 ml CC	ACD-A soluzione anticoagulante 1000 ml CC	8
RGR8109B	InterSol PAS 280 ml	InterSol PAS 280 ml	InterSol PAS 280 ml	18
RGB8110B	InterSol PAS 500 ml	InterSol PAS 500 ml	InterSol PAS 500 ml	10

non-DEHP



Fresenius Kabi ist kontinuierlich dabei das Portfolio auf die DEHP-freien* Alternativen umzustellen, selbstverständlich mit der bewährten Qualität und Leistung. *DEHP-Gehalt <0.1%

Fresenius Kabi adapte en permanence l'ensemble de son portefeuille vers des alternatives sans DEHP*, tout en conservant bien entendu la qualité et les performances éprouvées. *contenu DEHP <0.1%

Fresenius Kabi sta convertendo l'intero portafoglio di prodotti in alternative prive di DEHP*, naturalmente con la stessa qualità e le stesse prestazioni comprovate. *contenuto di DEHP <0.1%

Correct Connect

CORRECT
CONNECT



Das Correct Connect System wurde von einer Arbeitsgruppe der Apherese Industrie entwickelt und bietet für jede Apherese-Lösung einen neuen standardisierten Sicherheitsanschluss. Dies hilft, versehentliche Verwechslungen der Lösungen zu verhindern und vereinfacht die Aphereseverfahren für die Fachleute. (ISO 18250-8)

Le système Correct Connect a été développé par un groupe de travail de l'industrie de l'aphérèse et offre une nouvelle connexion de sécurité standardisée pour chaque solution d'aphérèse. Cela permet d'éviter le mélange accidentel des solutions et simplifie les procédures d'aphérèse pour les professionnels. (ISO 18250-8)

Il sistema Correct Connect è stato sviluppato da un gruppo di lavoro dell'industria dell'aferesi e offre una nuova connessione di sicurezza standardizzata per ogni soluzione per aferesi. Questo aiuta a prevenire la miscelazione accidentale delle soluzioni e semplifica le procedure di aferesi per i professionisti. (ISO 18250-8)

Inline-Systems

CQ31555 CompoFlow

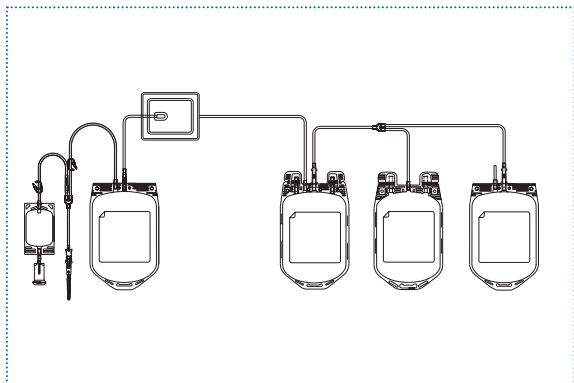

PQ31555 CompoSelect

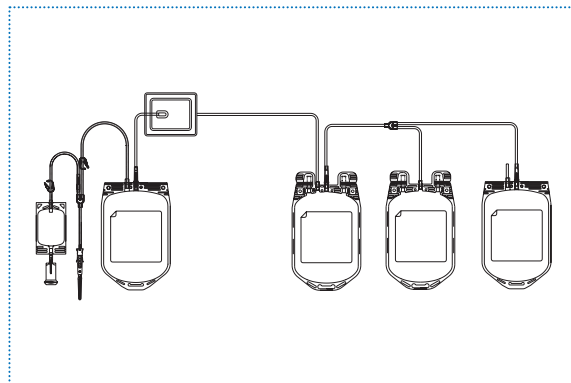

CQ32250 CompoFlow

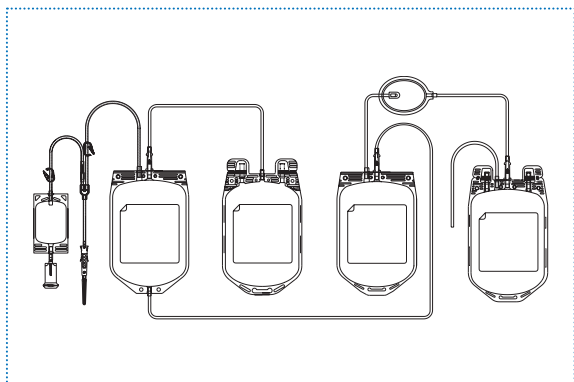

GQ42250 CompoFlow 

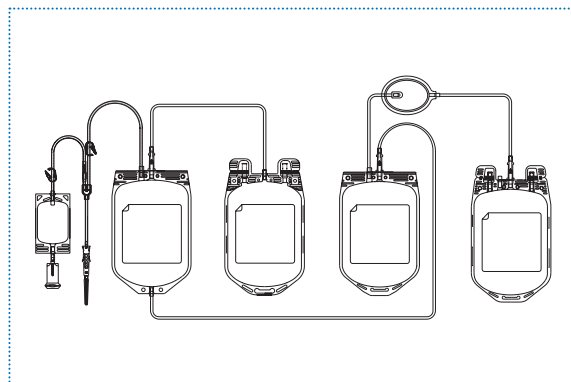

CQ32350 CompoFlow

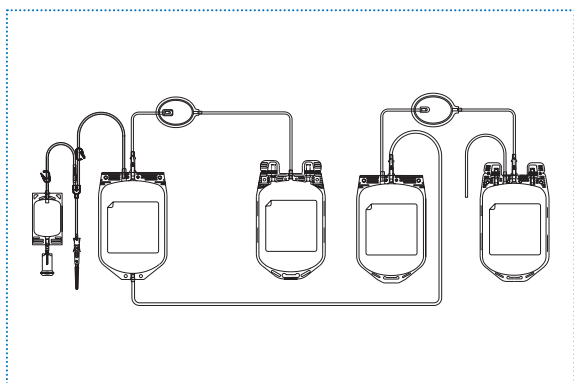

Art. No.	Information	Unit
CQ31555	CompoFlow 4F 63 ml CPD / 100 ml SAG-M Wbf+PDS-V	20
PQ31555	CompoSelect 4F 63 ml CPD / 100 ml SAG-M Wbf+PDS-V	20
CQ32250	CompoFlow 4F T&B 63 ml CPD / 100 ml SAG-M RCC PDS-V	24
GQ42250	CompoFlow 4F 63 ml CPD / 100 ml PAGGS-M RCC+PDS-V non-DEHP 	24
CQ32350	CompoFlow 4F T&B 63 ml CPD / 100 ml SAGM RCC/Plasma+PDS-V	20

Bloodbags

EQ06A0E CompoFlex empty 4x150ml 

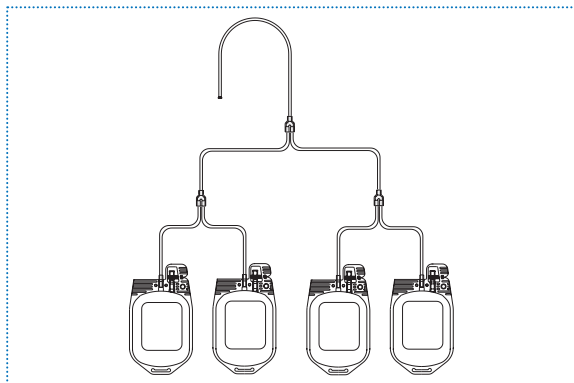

EQ06A0H CompoFlex empty 4x600ml 

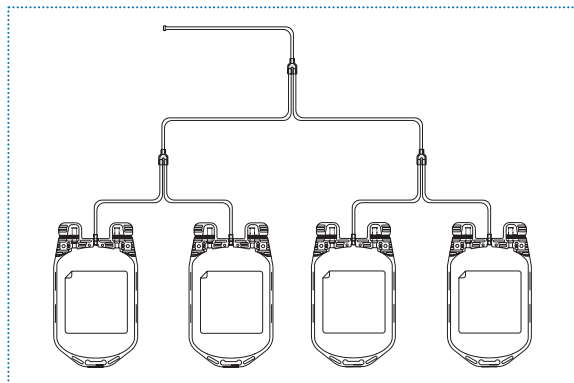

PD11150 CompoFlex 63 ml CPDA needle

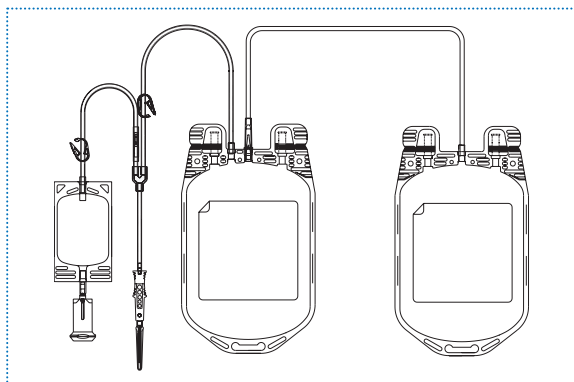

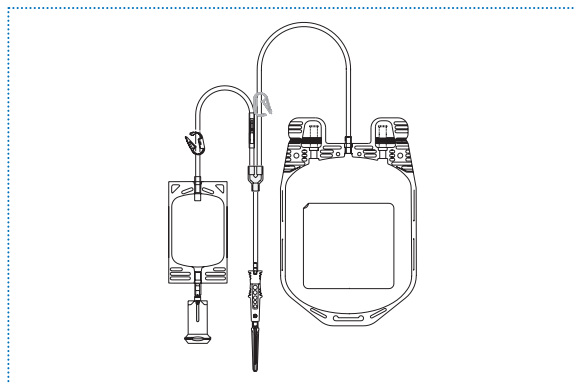

PS11140 CompoFlex 49 ml CPDA needle

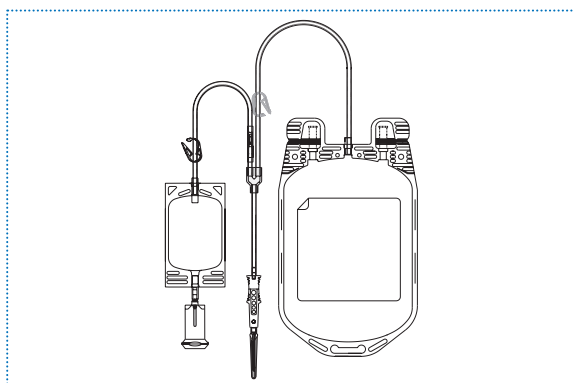

PS11150 CompoFlex 63 ml CPDA needle



Art. No.	Information	Unit
EQ06A0E	CompoFlex 4F Pediatric RCC 4x150ml non-DEHP 	40
EQ06A0H	CompoFlex 4F Pediatric RCC/PLT 4x600ml non-DEHP 	30
PD11150	CompoFlex 2F 63 ml - CPDA1 - PDS - V - 450 ml	36
PS11140	CompoFlex 1F 49 ml - CPDA1 - PDS - V - 350 ml	40
PS11150	CompoFlex 1F 63 ml - CPDA1 - PDS - V - 450 ml	36

Bloodbags

PT32150 CompoFlex 63 ml CPD 100 ml SAGM

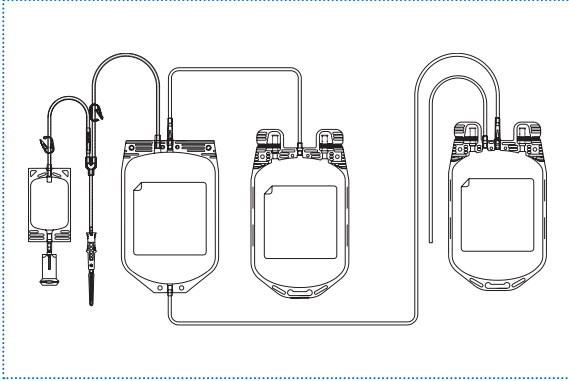

R6R2001 CompoFlex empty 150 ml coupler

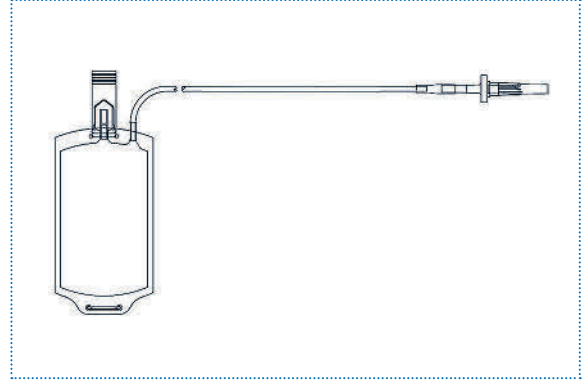

R6R2004 CompoFlex empty 4x150 ml coupler

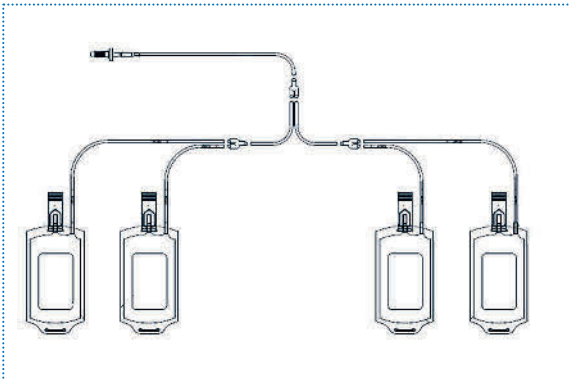

R6R2023 CompoFlex empty 600 ml coupler

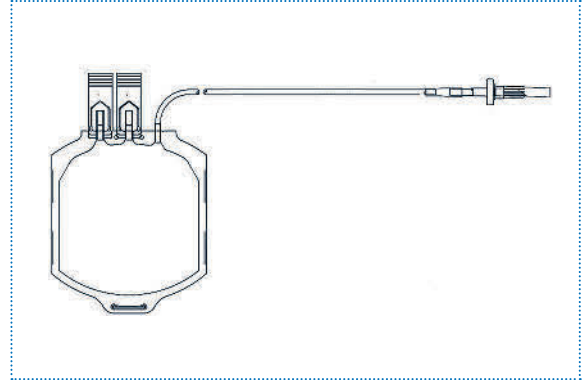

R6R2024 CompoFlex empty 600 ml luer

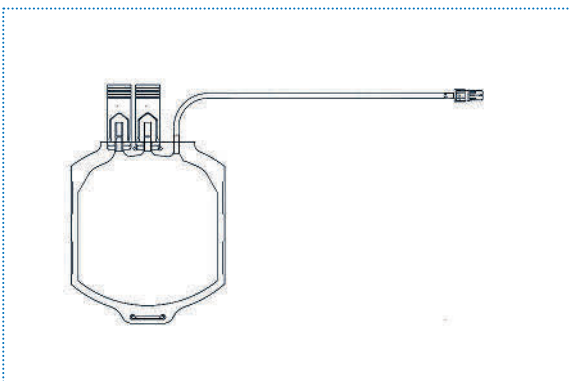

Art. No.	Information	Unit
PT32150	CompoFlex 3F T&B 63 ml - CPD/100ml SAGM - PDS/V - 450 ml	28
R6R2001	CompoFlex 1F empty 150 ml - coupler/seg tube	96
R6R2004	CompoFlex 4F empty 4x150 ml - coupler/seg tube	48
R6R2023	CompoFlex 1F empty 600 ml - coupler/seg tube	96
R6R2024	CompoFlex 1F empty 600 ml - luer/seg tube	48

Bloodbags

R6R2031 CompoFlex empty 1000ml coupler

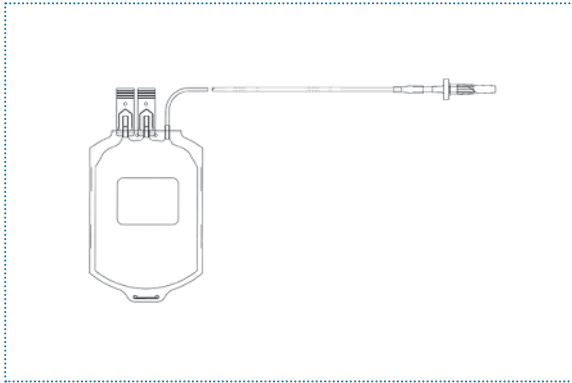

R6R2041 CompoFlex empty 2000 ml coupler

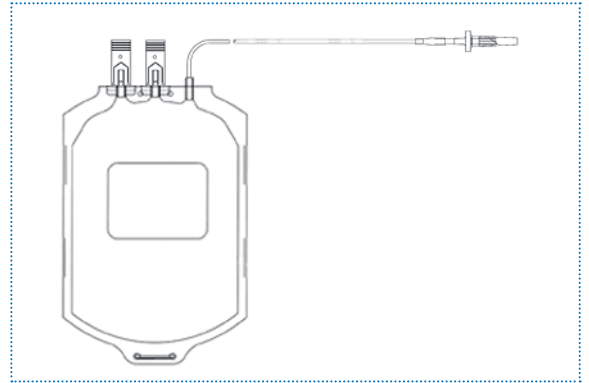

R6R2074 CompoFlex empty 400ml coupler

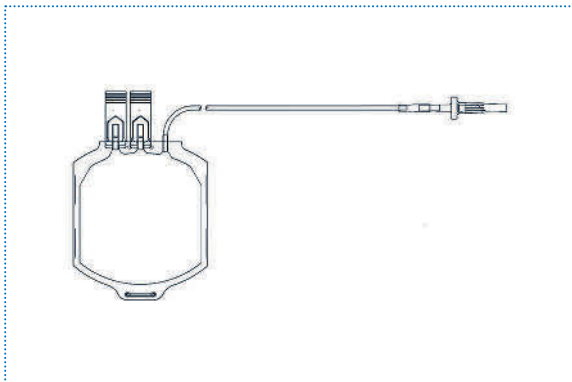

FS01A0K CompoFlex Plt storage 1300ml

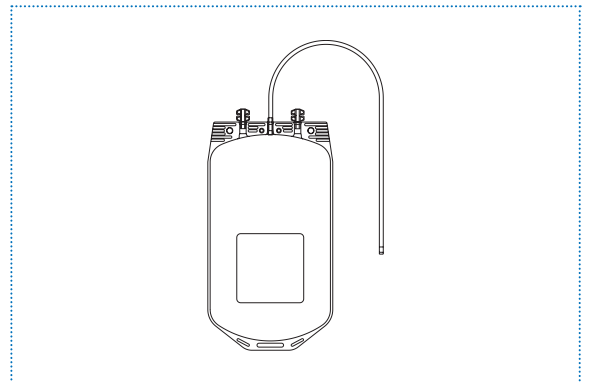

T2131 CompoFlex empty 600ml needle

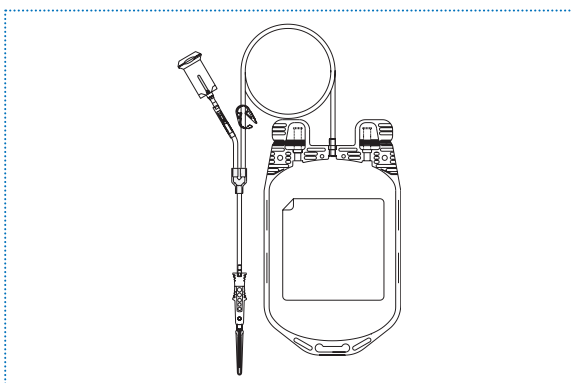

X6R2247 Transfer Pack empty 1000ml luer

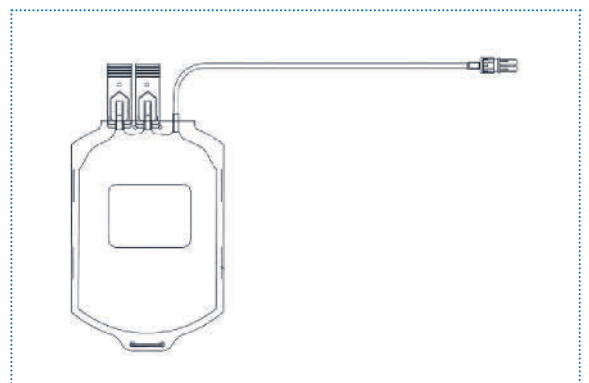

Art. No.	Information	Unit
R6R2031	CompoFlex 1F empty 1000 ml - coupler	48
R6R2041	CompoFlex 1F empty 2000ml - coupler/seg tube	48
R6R2074	CompoFlex 1F empty 400ml - coupler	48
FS01A0K	CompoFlex 1F 1300ml - PLT storage non-DEHP	50
T2131	CompoFlex 1V empty 600 ml	50
X6R2247	Transfer Pack 1000ml - luer	96

Filter

9009571 BioR Filter

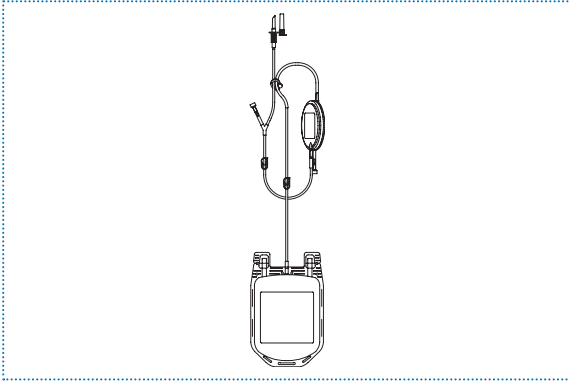

AS01910 BioR Flex Filter

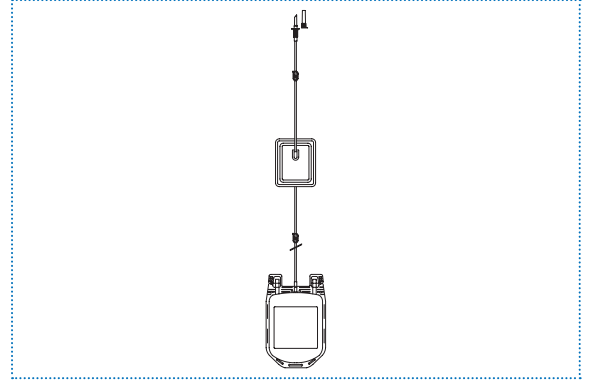

Leukozytendepletion für Erythrozytenkonzentrate

Déplétion leucocytaire pour les concentrés érythrocytaires

Deplezione di leucociti per i concentrati di globuli rossi

FD51600 CompoStop 

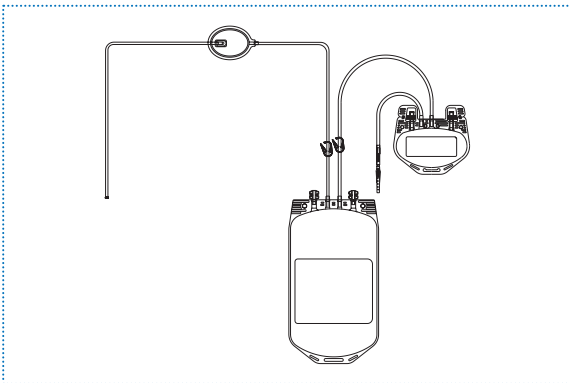

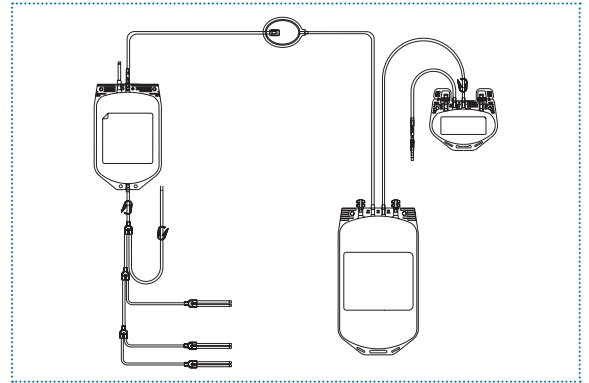

FT52600 CompoStop 



Leukozytendepletion für Thrombozytenkonzentrate

Déplétion leucocytaire pour les concentrés de plaquettes

Deplezione di leucociti per i concentrati piastrinici

Art. No.	Information	Unit
9009571	BioR Filter BBS Max 1 BBS	40
AS01910	BioR Flex Filter	25
FD51600	CompoStop 2F T&B 6 PLT Pooling system Train non-DEHP 	40
FT52600	CompoStop 3F T&B 6 PLT Pooling system Octopus non-DEHP 	30

Accessoires

R6R1401 Verbindungsstange mit Injektionsanschluss

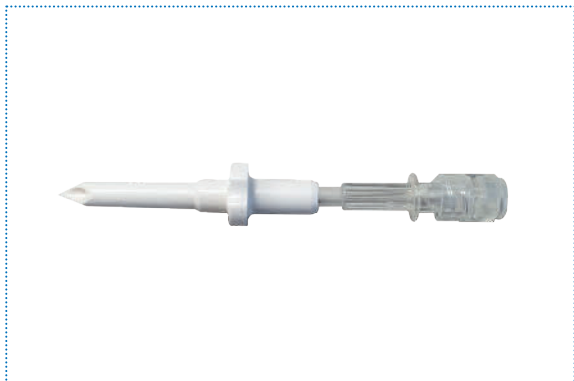

R6R2134 Transfusions-Set für Thrombozyten

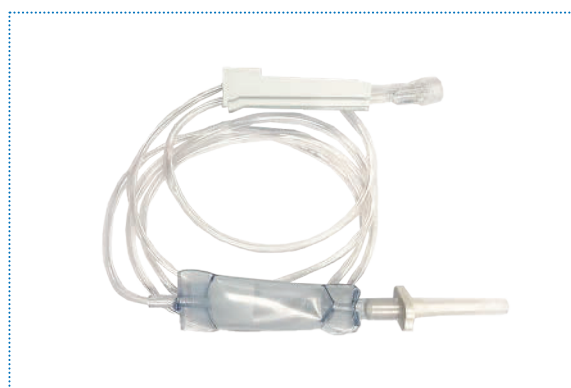

2845241 Scissor Gefäßklemme Plastik



6R4452 Schlauchabstreifer

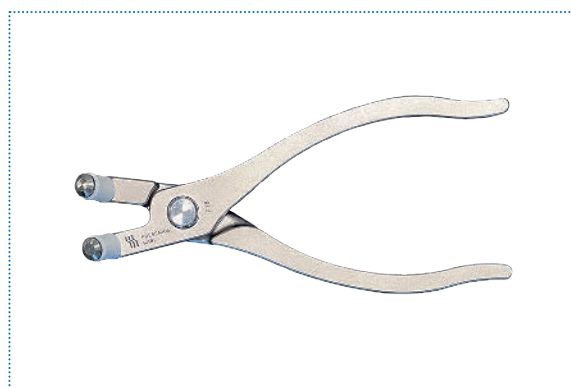

Art. No.	Information			Unit
R6R1401	Verbindungsstange mit Injektionsanschluss	Perf. avec site d'injection	Perf. con attacco d'iniezione	phase out 100
R6R2134	Transfusions-Set für Thrombozyten	Set de transfusion pour plaquettes	Set per trasfusione di piastrine	phase out 100
2845241	Scissor Gefäßklemme Plastik	Clamp en plastique	Pinza di plastica	5
6R4452	Schlauchabstreifer	Pince à stripper	tergicristallo per tubi	1

CompoGuard®



9029601
Basic



9029611
Data



9029621
Complete

Die CompoGuard® Blutmischwaage verbindet hohe Sicherheit mit Effizienz in der Vollblutspende.

La balance de mélange sanguin CompoGuard® allie haute sécurité et efficacité dans le don de sang total.

La bilancia per la miscelazione del sangue CompoGuard® combina alta sicurezza con l'efficienza nella donazione di sangue intero.



Art. No.	Information			Unit
9029601	CompoGuard Basic	CompoGuard Basic	CompoGuard Basic	1
9029611	CompoGuard Data	CompoGuard Data	CompoGuard Data	1
9029621	CompoGuard Complete	CompoGuard Complete	CompoGuard Complete	1
9028331	CompoGuard Netzwerk-Konverter RS485	CompoGuard Convertisseur réseau RS485	CompoGuard Convertitore di rete RS485	1
9029001	CompoGuard DECT-Fixedpart Klon	CompoGuard DECT-Fixedpart clon	CompoGuard DECT-Fixedpart clone	1
9029331	Donationmaster Net mehrsprachig	Donationmaster Net multilingue	Donationmaster Net multilingue	1
9029471	Transportkoffer ohne Ladeoption	Caisse de transport sans chargeur	Custodia da trasporto senza ricarica	1
9029481	Transportkoffer mit Ladeoption	Caisse de transport avec chargeur	Valigetta di trasporto con ricarica	1
9029491	Ladegerät 4-fach für Li-Ion Akku	Chargeur quadruple pour batterie Li-Ion	Caricabatterie 4vol. per batteria Li-Ion	1
9029501	CompoGuard Akkupack (gelb)	CompoGuard Batterie (jaune)	CompoGuard Pacco batteria (giallo)	1
9029531	CompoGuard «Schwanenhals» Scannerhalter	CompoGuard «Col de cygne» support scanner	CompoGuard «Collo d'oca» supporto scanner	1
9029541	CompoGuard USB 2.0 Stick 4GB	CompoGuard USB 2.0 4GB	CompoGuard USB 2.0 4GB	1
9029671	Barcode Scanner F560 + Halter	Scanner de codes barres F560 + support	Scanner di codici a barre F560 + supporto	1
9025611	Barcode Scanner F560	Scanner de codes à barres F560	Scanner di codici a barre F560	1
M68705ISP	CompoGuard Li-Ion Akku bis 70 Spenden	CompoGuard Batterie Li-Ion jusqu'à 70 dons	CompoGuard Batteria Li-Ion fino 70 donazioni	1
M68975ISP	Handschweisszange	Pince à souder	Sigillatrice a mano	1

CompoSeal® Mobilea II



CompoSeal® Mobilea II, das Schlauchschweissgerät für den mobilen Einsatz

CompoSeal® Mobilea II, la soudeuse de tuyaux pour une utilisation mobile

CompoSeal® Mobilea II, il dispositivo di saldatura per tubi flessibili per uso mobile

Art. No.	Information			Unit
9027011	CompoSeal Mobilea II Set	CompoSeal Mobilea II Set	CompoSeal Mobilea II Set	1
9024031	CompoSeal Mobilea II Handschweisszange	CompoSeal Mobilea II pince à souder	CompoSeal Mobilea II sigillatrice a mano	1
9027001	CompoSeal Mobilea II Powerpack	CompoSeal Mobilea II batterie	CompoSeal Mobilea II batteria	1
9027031	CompoSeal Mobilea II Ladegerät	CompoSeal Mobilea II bloc d'alimentation	CompoSeal Mobilea II caricatore	1
9027041	Mobilea II Kabel für Handschweisszange	Mobilea II câble pour pince à souder	Mobilea II cavo per sigillatrice a mano	1
9027051	Mobilea II Transportkoffer	Mobilea II coffret de transport	Mobilea II valigia di trasporto	1

CompoMat® G5 Plus



CompoMat® G5 Plus, das System für die automatisierte Blutkomponentenseparation

CompoMat® G5 Plus, le système pour la séparation automatisée des composants sanguins

CompoMat® G5 Plus, il sistema per la separazione automatizzata dei componenti del sangue

Art. No.	Information			Unit
9026501	CompoMat G5 Plus	CompoMat G5 Plus	CompoMat G5 Plus	1
9026511	CompoMat G5 Plus RCC Waage	CompoMat G5 Plus RCC balance	CompoMat G5 Plus RCC bilancia	1
9026521	CompoMat G5 Plus PLC Waage	CompoMat G5 Plus Plasma balance	CompoMat G5 Plus PLC bilancia	1
9025531	CompoMat G5 Filterhalter RCC	CompoMat G5 porte-filtre RCC	CompoMat G5 portafiltri RCC	1
9025541	Compomaster Net G5 CD & IFU	Compomaster Net G5 CD & mode d'emploi	Compomaster Net G5 CD & istruzioni l'uso	1
9025581	CompoMat G5 Filterhalter (38 cm ²)	CompoMat G5 porte-filtre (38 cm ²)	CompoMat G5 portafiltri (38 cm ²)	1
9025591	CompoMat G5 Filterhalter (15 cm ²)	CompoMat G5 porte-filtre (15 cm ²)	CompoMat G5 portafiltri (15 cm ²)	1
9025611	CompoMat Barcode Scanner F560	CompoMat scanner de codes à barres F560	CompoMat scanner di codici a barre F560	1
M724241SP	CompoSure M	CompoSure M	CompoSure M	1

CompoLab TM



CompoLab TM ist ein mobiles, schnelles und ergonomisches Hämoglobinmessgerät.

CompoLab TM est un appareil de mesure de l'hémoglobine mobile, rapide et ergonomique.

CompoLab TM è un misuratore di emoglobina mobile, veloce ed ergonomico.

Art. No.	Information			Unit
9034000	CompoLab TM	CompoLab TM	CompoLab TM	1
9034050	CompoLab TM Küvetten	CompoLab TM cuvettes	CompoLab TM cuvettes	500
90B.0012	Diaspect Control Pack medium	Diaspect Control Pack medium	Diaspect Control Pack medium	3
90B.0014	Diaspect Control Pack (HB low/med/high)	Diaspect Control Pack (HB low/med/high)	Diaspect Control Pack (HB low/med/high)	1
M693010SP	CompoLab TM Küvettenhalter	Porte-cuvette CompoLab TM	Portaprovette CompoLab TM	1
9034010	CompoLab TM Transportkoffer	CompoLab TM caisse de transport	CompoLab TM valigia di trasporto	1

Manual Plasma Extractor



Erzeugt einen konstanten Druck von unten nach oben, um Plasma/Thrombozyten aus Vollblut zu extrahieren.

Offre une pression constante de bas en haut pour extraire le plasma et les plaquettes du sang total.

Fornisce una pressione costante dal basso verso l'alto per l'estrazione del plasma e delle piastrine dal sangue intero.

Art. No.	Information			Unit
9024201	Manual Plasma Extractor	Extracteur de plasma manuel	Estrattore di plasma manuale	1

Autotransfusion CATSmart®



CATSmart®, das kontinuierliche Autotransfusionssystem für sicheres Blutmanagement

CATSmart®, le système d'autotransfusion pour un meilleur confort d'utilisation et une plus grande sécurité des patients

CATSmart®, Il sistema di autotrasfusione per un maggiore comfort dell'utente e per la sicurezza del paziente

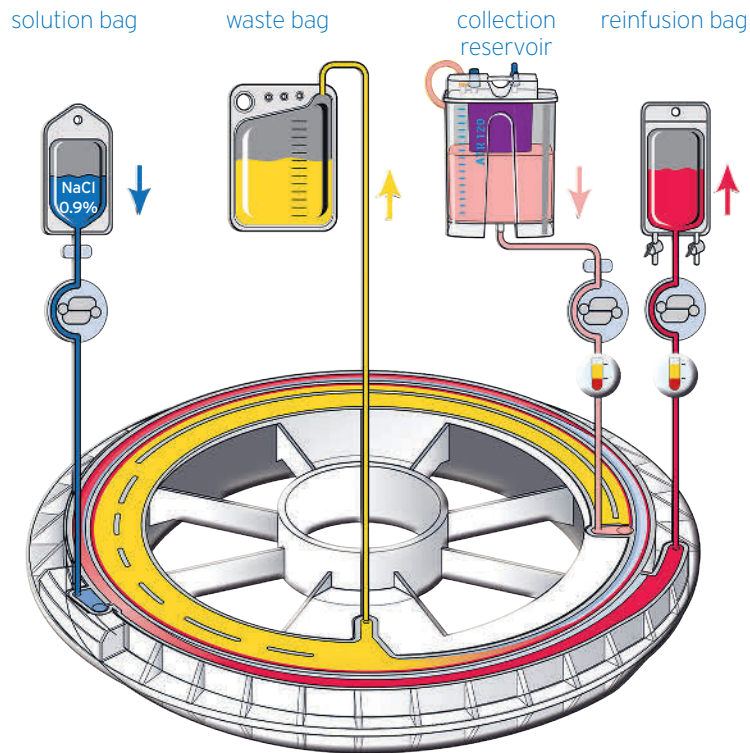

Das Prinzip der kontinuierlichen Blutaufbereitung.
 Le principe de la préparation continue du sang.
 Il principio della preparazione continua del sangue.

Art. No.	Information			Unit	
9005751	CATSmart	CATSmart	CATSmart	1	
9005761	Ablageschale für CATSmart	Plateau de rangement pour CATSmart	Vassoio per CATSmart	1	
9005851	Vakuumeinheit für CATS	Unité sous vide pour CATS	Unità vuoto per CATS	1	
9005861	Autostart Reservoir Halter	Support de réservoir autostart	Supporto di riserva autostart	1	
9005871	Schutz für Zentrifugendeckel	Protection de couvercle de centrifugeuse	Protezione di copertura della centrifuga	1	
9028911	Vakuumregler FinaVac 800	Régulateur de vide FinaVac 800	Regolatore vuoto FinaVac 800	1	
M649951	Überlaufschutz CATS	Protection antidébordement CATS	Protezione contro il trabocco CATS	1	
M679011	Rauchfilter für Vakuumeinheit	Filtre à fumée pour unité de vide	Filtro fumo per unità vuoto	1	
6780881	Filterblatt für CATS (Box 100 Stk.)	Feuille filtrante pour CATS (100 pcs)	Fogli filtro per CATS (100 pezzi)	100	
M700831SP	ATH-Reservoirhalterung	Support de réservoir ATH	Supporto di serbatoio	1	
AS0191C	Leukodepletionsfilter BioR flex AT	Filtre de déleucocytation BioR flex AT	Filtro BioR flex AT	25	
MDR	MDD	Information		Unit	
9005101	9305101	AT1 Autotransfusions Set	AT1 Set d'autotransfusion	AT1 Set di autotrasfusione	8
9005103	9305103	AT3 Autotransfusions Set (CATSmart)	AT3 Set d'autotransfusion (CATSmart)	AT3 Set di autotrasfusione (CATSmart)	8
9005161	9305161	Reinfusionsbeutel 1000ml, mit Y-Leitung	Poche à c.g. 1000ml avec Y-adaptateur	Sacco reinfusione 1000ml, Y-adattatore	20
9005201	9305201	Reinfusionsbeutel 1000ml	Poche à c.g. 1000ml	Sacco per reinfusione 1000ml	20
9005361	9305361	Vakuuadapter ATR	Adaptateur de vide ATR	Adattatore vuoto ATR	16
9006281	9306281	Abfallbeutel, 10L	Poche à déchets, 10L	Sacco per scarto, 10L	5
9008551	9308551	ATV-F140C Vakuuleitung Kombi-Pack	ATV-F140C tube de vide pack combiné	ATV-F140C Linea vuoto pacco combi	12
9108401	9308401	ATY Y-Adapter	ATY Y-adaptateur	ATY Y-Adattatore	8
9108451	9308451	ATP Post OP Set	ATP set post OP	ATP set post intervento	16
9108471	9308471	ATR 120 Reservoir	ATR 120 reservoir	ATR 120 serbatoio	8
9108481	9308481	ATS Saugleitung	Conduite d'aspiration ATS	ATS linea aspirazione	20
9108552	9308552	ATV-70 Vakuuleitung 70cm	ATV-70 ligne de vide 70cm	ATV-70 linea vuoto 70cm	15
9108553	9308553	ATV-180 Vakuuleitung, 180cm	ATV-180 ligne de vide, 180cm	ATV-180 linea vuoto, 180cm	12

Cell Processing LOVO



LOVO, das automatisierte Zellverarbeitungssystem

LOVO, le système automatisé de traitement des cellules

LOVO, il sistema di trattamento cellulare automatizzato

Art. No.	Information			Unit
6R4900	Lovo Instrument (für Therapie)	Lovo Instrument (pour thérapie)	Lovo Instrument (per la terapia)	1
6R4900C	Lovo Med Zellverarbeitungssystem mit CE	Lovo système de traitement cellules CE	Lovo sistema di lavorazione cellulare CE	1
X6R4909A	Lovo Einwegset	Lovo set à usage unique	Lovo set monouso	6
X6R4907	Lovo Pouch Einwegset	Lovo Pouch Set à usage unique	Set di sacchetti monouso Lovo	6
X6R4917	Lovo Ventil- und Filter-Einwegset	Set à usage unique valve, filtre Lovo	Set monouso con valvola e filtro Lovo	6
X6R4902	Lovo Zusatzbeutelset	Lovo kit de poche auxiliaire	Lovo circuito della sacca ausiliaria	20
YM020	ViaLok Flaschenverbindungsstück	ViaLok dispositif d'accès flacon ventilé	ViaLok dispositivo di accesso al flacone	100

Cell Processing CUE



CUE ist ein automatisiertes Zellverarbeitungssystem für kleine Volumina.

CUE est un système de traitement cellulaire automatisé pour les petits volumes.

CUE è un sistema di trattamento cellulare automatizzato per piccoli volumi.

Art. No.	Information			Unit
6R5000	Cue Instrument (für Therapie)	Cue Instrument (pour thérapie)	Cue Instrument (per la terapia)	1
X6R5002	Cue Verteilerset 8-lead	Cue set de collecteur 8-lead	Cue set di collettore 8-lead	10
X6R5004	Cue Einwegset - 4µm	Cue set à usage unique - 4µm	Cue set monouso - 4µm	4

Fresenius Kabi (Schweiz) AG

Ihre Bestellung

Telefon 0800 820 280
Fax 0800 820 281
Email customerservice.ch@fresenius-kabi.com

Öffnungszeiten von Montag bis Freitag
8.00 - 12.00 / 13.00 - 17.00

Unsere Aussendienstmitarbeitenden freuen sich auf Ihre Kontaktaufnahme.

Votre commande

Téléphone 0800 820 280
Fax 0800 820 281
Email customerservice.ch@fresenius-kabi.com

Heures d'ouverture du lundi au vendredi
8.00 - 12.00 / 13.00 - 17.00

Nos collaboratrices et collaborateurs du service extérieur se réjouissent de votre prise de contact.

Il vostro ordine

Telefono 0800 820 280
Fax 0800 820 281
Email customerservice.ch@fresenius-kabi.com

Orari di apertura da lunedì a venerdì
8.00 - 12.00 / 13.00 - 17.00

Il nostro personale di assistenza sul campo è lieto di ricevere la vostra attenzione.

Die mit ® gekennzeichneten Zeichen/Namen sind in ausgewählten Ländern eingetragene Marken der Fresenius Gruppe.
Les signes/noms avec ® sont des marques déposées du groupe Fresenius dans les pays sélectionnés.
I simboli/nomi contrassegnati con ® sono marchi registrati del Gruppo Fresenius in determinati Paesi.



**FRESENIUS
KABI**

caring for life

Fresenius Kabi (Schweiz) AG
Am Mattenhof 4
6010 Kriens

Telefon 041 552 70 00
info.ch@fresenius-kabi.com
www.fresenius-kabi.ch